

# NEUROLOGY

## **Neuropsychological and neurophysiologic effects of carbamazepine and levetiracetam**

K. J. Meador, A. Gevins, D. W. Loring, L. K. McEvoy, P. G. Ray, M. E. Smith, G. K. Motamedi, B. M. Evans and C. Baum

*Neurology* 2007;69;2076-2084

DOI: 10.1212/01.wnl.0000281104.55418.60

**This information is current as of November 27, 2007**

The online version of this article, along with updated information and services, is located on the World Wide Web at:

<http://www.neurology.org/cgi/content/full/69/22/2076>

*Neurology*® is the official journal of the American Academy of Neurology. Published continuously since 1951, it is now a weekly with 48 issues per year. Copyright © 2007 by AAN Enterprises, Inc. All rights reserved. Print ISSN: 0028-3878. Online ISSN: 1526-632X.



# Neuropsychological and neurophysiologic effects of carbamazepine and levetiracetam



K.J. Meador, MD  
A. Gevins, DSc  
D.W. Loring, PhD  
L.K. McEvoy, PhD  
P.G. Ray, PhD  
M.E. Smith, PhD  
G.K. Motamedi, MD  
B.M. Evans, BS  
C. Baum, MS

Address correspondence and reprint requests to Dr. Kimford J. Meador, Department of Neurology, University of Florida (PO Box 100236), McKnight Brain Institute (L3-100), 100 South Newell Drive, Gainesville, FL 32610  
kimford.meador@neurology.ufl.edu

## ABSTRACT

**Background:** The relative effects of levetiracetam (LEV) and carbamazepine (CBZ) on cognitive and neurophysiologic measures are uncertain.

**Methods:** The effects of LEV and CBZ were compared in healthy adults using a randomized, double-blind, two-period crossover design. Outcome measures included 11 standard neuropsychological tests and the score from a cognitive-neurophysiologic test of attention and memory. Evaluations were conducted at screening, baseline pre-drug treatment, end of each maintenance phase (4 weeks), and end of each washout period after drug treatment.

**Results:** A total of 28 adults (17 women) with mean age of 33 years (range 18 to 51) completed the study. Mean maintenance doses ( $\pm$ SD) were CBZ = 564 mg/day (110) and LEV = 2,000 mg/day (0). CBZ was adjusted to mid-range therapeutic level. Mean serum levels ( $\pm$ SD) were CBZ = 7.5 mcg/mL (1.5) and LEV = 32.2 mcg/mL (11.2). An overall composite score including all measures revealed worse effects for CBZ compared to LEV ( $p \leq 0.001$ ) in the primary analysis and for CBZ ( $p \leq 0.001$ ) and LEV ( $p \leq 0.05$ ) compared to non-drug in secondary analyses. Across the 34 individual variables, CBZ was worse than LEV on 44% (15/34); none favored CBZ. Compared to the non-drug average, CBZ was worse for 76% (26/34), and LEV was worse for 12% (4 of 34). Sensitivity and specificity of standard neuropsychological tests and the cognitive-neurophysiologic test were determined to direct future studies; detection was most accurate by the cognitive-neurophysiologic test.

**Conclusions:** Levetiracetam produces fewer untoward neuropsychological and neurophysiologic effects than carbamazepine in monotherapy at the dosages and timeframes employed in this study. *Neurology*® 2007;69:2076-2084

## GLOSSARY

**ABL** = anticonvulsant blood level; **AED** = antiepileptic drug; **ANOVA** = analysis of variance; **CBZ** = carbamazepine; **ERP** = event-related potential; **LDA** = linear discriminant analysis; **LEV** = levetiracetam; **POMS** = Profile of Mood States; **POz** = parieto-occipital site; **SAM** = Sustained Attention and Memory; **SEALS** = Side Effects and Life Satisfaction Scale; **QOLIE-89** = Quality of Life in Epilepsy-89; **VSAT** = Visual Serial Addition Test; **WM** = working memory.

Levetiracetam (LEV) is a new antiepileptic drug (AED) found to have good efficacy in adjunctive therapy for partial seizures with and without secondary generalization.<sup>1,2</sup> The present study investigated the neuropsychological and cognitive-neurophysiologic effects of LEV compared to carbamazepine (CBZ) in healthy subjects employing a double-blind, two period crossover design. AEDs are known to affect EEG and event-related potentials (ERPs).<sup>3-6</sup> Further, several recent studies have established that inclusion of EEG or ERP measures can provide more sensitive detection of the impact of pharmacologic interventions and sleep deprivation on CNS activity than can be achieved with neuropsychological or psychometric task performance measures alone.<sup>6-9</sup> Thus, in addition to the conventional neuropsychological tests, this study also employed a combined cognitive-

Supplemental data at  
[www.neurology.org](http://www.neurology.org)

From the Departments of Neurology (K.J.M., D.W.L.) and Clinical and Health Psychology (D.W.L.), University of Florida, Gainesville; San Francisco Brain Research Institute and SAM Technology (A.G., L.K.M., M.E.S., M.E.S., B.M.E., C.B.), CA; Department of Neurology (P.G.R.), Medical College of Georgia, Augusta; and Department of Neurology (G.K.M.), Georgetown University, Washington, DC.

Supported by a grant from UCB Pharma to Dr. Meador. The cognitive neurophysiologic component of this study was supported by a grant from the NINDS to Dr. Gevins.

*Disclosure:* Drs. Loring and Motamedi have received honoraria from UCB Pharma.

neurophysiologic measure, the Sustained Attention and Memory (SAM) examination,<sup>6-19</sup> to evaluate the effects of CBZ and LEV.

The primary analysis was a direct comparison of the two AEDs using an overall component score that combined all the neuropsychological test measures and the SAM examination score into a single number. The standard neuropsychological tests have been used in several prior studies<sup>20-26</sup> and were also analyzed separately here to allow direct comparison of these measures to the results of prior studies. Although not the primary purpose of the study, comparisons of each AED to the nondrug condition were also made. In addition, the sensitivity and specificity of the standard neuropsychological measures and the cognitive-neurophysiologic measures were assessed to help direct future studies delineating AED effects and examining physiologic mechanisms of AED-induced cognitive effects.

**METHODS** **Subjects.** The subjects were healthy paid adult volunteers without history of neurologic or psychiatric diseases including drug abuse. Informed consent was obtained according to the Declaration of Helsinki. No subject was on centrally active medications at the time of enrollment, and all had negative urine drug screens. All subjects remained free of centrally active prescription medications throughout the study. They also did not use over-the-counter medications or alcohol for 72 hours prior to each cognitive testing session.

**Standard neuropsychological outcome measures.** IQ was assessed at enrollment by the Peabody Picture Vocabulary Test.<sup>27</sup> The neuropsychological battery to assess AED effects consisted of 11 tests with a total of 33 variables, which spanned five neurobehavioral domains. Many of the tasks have been shown to be sensitive to AEDs and have been employed in prior studies.<sup>20-26</sup> The battery assessed the following: 1) Attention/vigilance: Digit Cancellation Test<sup>28</sup> (timed detection task of a specific number from sheet of numbers), Visual Serial Addition Test<sup>23</sup> (VSAT is a visual analog of the PASAT; VSAT requires the subject to repetitively add the last two numbers given in a continuing series of numbers); 2) Memory: MCG Paragraph Memory<sup>22</sup> (immediate recall of paragraphs I and II and delayed recall of paragraph I; parallel forms used for different test days); 3) Cognitive and motor speed: Lafayette Grooved Pegboard<sup>29</sup> (test of coordinated motor speed), Choice Reaction Time: initiation, movement, and total time<sup>30</sup>; 4) Other cognitive tests: Stroop<sup>31</sup> (timed tests of reading words, naming colors, and combined word-color interference task), Symbol Digit Modalities Test<sup>32</sup> (timed graphomotor coding task); 5) Subjective behavioral measures: A-B Neurotoxicity Scale<sup>33</sup> (24-item questionnaire to assess adverse symptoms associated with AEDs), Profile of Mood States<sup>34</sup> (POMS = adjective

checklist to assess mood; subscales include Tension/Anxiety, Depression, Anger/Hostility, Vigor, Fatigue, and Confusion/Bewilderment), Side Effects and Life Satisfaction Scale<sup>35</sup> (SEALS = general quality of life scale with five scales: dysphoria, tiredness, cognition, anger/temper and worry), and the three Cognitive Scales (i.e., attention, language, and memory) from the Quality of Life in Epilepsy-89<sup>36</sup> (QOLIE-89; an 89-item quality of life scale for patients with epilepsy).

**SAM examination.** EEG, ERP, and cognitive performance measures were collected in the context of a short computerized cognitive task battery designed for concomitant EEG recording during working memory (WM) and episodic memory tests. Working memory was assessed using a spatial n-back WM task; we have used similar versions of this task in basic cognitive neurophysiologic research<sup>14-16,19</sup> and studies of drugs, sleep deprivation, and therapeutic treatments.<sup>5-13,17,18</sup> In the version employed here across 50 different blocks of 4-second trials, subjects compared the location of a stimulus on the current trial with the location of the stimulus presented on the prior trial ("1-back" or low WM load task), or compared it with the location of the stimulus presented two trials previously ("2-back" or high WM load task), indicating decisions by key press responses. Episodic memory was assessed using a delayed 24-word recognition task, with 4-minute spatial working memory tasks interposed as a distracter before delayed recognition.<sup>9,13,18</sup> Neurophysiologic correlates of such word recognition tasks have been well studied.<sup>9,13,37-41</sup> The episodic memory task was repeated twice with the same 24-word recognition list and different non-target words. EEG was recorded continuously during performance of this cognitive task battery from seven scalp locations (F3, F4, FZ, CZ, P3, P4, and POz) referenced to linked mastoids. In prior studies, these locations were found to be most sensitive to effects of task difficulty, variations in alertness, and drug effects on the working memory and episodic memory tasks.<sup>5,7,8,10-19</sup> Potentials generated by eye movements and blinks were recorded by electrodes positioned at the outer canthus and above the superior orbital ridge of each eye. EEG signals were sampled at 128 Hz and bandpass filtered from 0.1 to 35 Hz. Automated artifact detection and artifact decontamination filters were used to minimize contaminants induced by eye movements and other sources. All data were then visually inspected, and data segments containing possible residual artifacts were excluded from further analyses.

**Procedure.** The study employed a double-blind, randomized, two-period crossover design. There were 12 visits over a 25-week time period (figure 1). Subjects were screened and tested at the non-drug baseline, and then randomly assigned to receive each AED for 8 weeks, which included a titration period and a 1-month maintenance period. Each AED treatment period was followed by a 4-day taper and a washout period for the remainder of the 4 weeks. Then, subjects were treated with the second AED for 8 weeks followed by a final 4-week washout period. Subjects were asked to have their routine duration of sleep the night before testing and a routine breakfast on the day of testing.

Prior to the first AED treatment, subjects underwent a physical examination, urine drug screen, and blood work (hematology and chemistry panel). A pregnancy test was conducted in women of childbearing potential prior to each AED treatment. Blood for anticonvulsant levels was drawn every 2 weeks during AED treatments (2 hours after morning

**Figure 1** Study design

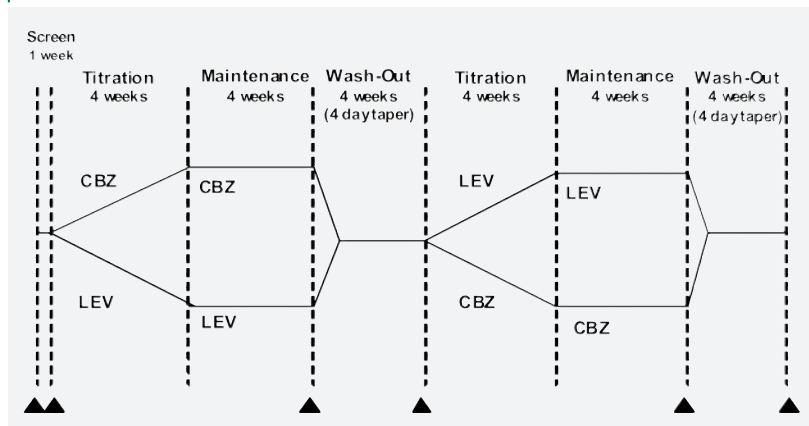

Carbamazepine (CBZ) titration: 200 mg/day  $\times$  1 week, 200 mg BID  $\times$  1 week, then adjusted to midrange blood levels with TID dosing. Levetiracetam (LEV) titration: 500 mg/day  $\times$  2 weeks, 500 mg BID  $\times$  2 weeks, then 1,000 mg BID. Neuropsychological testing denoted by black triangles.

...). Hematology and liver function were re-assessed during AED treatments and at the end of the final washout. Neuropsychological testing was conducted at screening and repeated at baseline prior to AED treatment, at the end of each AED treatment phase, and at the end of each washout phase after each drug treatment (4 weeks after the neuropsychological assessments at the end of maintenance for each AED treatment). Thus, subjects underwent neuropsychological and cognitive-neurophysiologic testing on six occasions (i.e., two AED conditions and four non-drug conditions) over 25 weeks (figure 1). Cognitive tests were performed in a fixed order at the same time of day (beginning approximately 2 hours after morning dose). The testing at screening was conducted to train subjects on the cognitive-neurophysiologic task battery and to familiarize them with EEG recording procedures and the neuropsychological tests. Results from the screening were not included in the analyses.

Matched capsules containing CBZ 200 mg or LEV 500 mg were used. During the AED treatment phase, subjects received a constant number of capsules TID daily (active drug plus placebo) in pillboxes containing a 2-week supply. Active drug dosages were gradually increased to a maintenance dose by replacing placebos with active capsules. CBZ was given at 200 mg/day for the first week, 200 mg/day BID for the second week, then adjusted to midrange anticonvulsant blood levels (ABLs) at TID dosages. LEV was begun at 500 mg/day for 2 weeks, then increased to 500 mg BID for 2 weeks, then increased to 1,000 mg BID. At the end of each AED treatment phase, subjects were tapered off AED over 4 days by replacing the active drug capsules with placebos. The remainder of a 4-week washout period occurred off drug prior to initiating the next drug period or the final non-drug washout testing. The subjects and all investigators in direct contact with the subjects were blinded as to drug and dosage.

**Analyses.** The primary analysis was a direct comparison of the two AEDs. To limit the number of variables analyzed and to control experiment-wise error rates, results from the standard neuropsychological tests and the cognitive-neurophysiologic test were combined together to form a single composite overall outcome measure. Specifically, data

were first reduced to six domains (attention/vigilance, memory, cognitive/motor speed, other cognitive/executive function, subjective, and SAM examination) and then averaged together (table 1). For each domain, all data were standardized within subject across all drug and non-drug conditions and then averaged together, weighted positively or negatively according to whether a lower score represents a decrement in subjective condition or task performance, or an adverse neurophysiologic response. SAM examination task performance was characterized by accuracy and reaction time during the two-back working memory and word recognition tasks.<sup>6-9,13,18-19</sup> The systemic effect of the drugs on mass brain electrical activity was characterized by EEG power in the delta and theta band and peak alpha frequency.<sup>7,13,42</sup> Event-related potential measures included latency and amplitude and of the working memory task parietal P300 and word recognition task frontal slow wave.<sup>6,7,13-16,18,19</sup>

To examine the main effects of CBZ vs LEV, the overall variable was entered into a  $2 \times 2$  repeated-measures analysis of variance (ANOVA) with drug and drug order as factors. Follow-up analyses comparing the two AEDs across individual variables were conducted using paired *t* tests. Additional post hoc analyses of the neurophysiologic measures were made to provide insight into the EEG/ERP effects.

To measure any changes attributable to repeated exposure to the task battery, a separate ANOVA was conducted that examined changes in the overall variable across the non-drug states (e.g., baseline, first drug washout period, and second drug washout period).

Although the primary aim of the study was to directly compare the two AEDs, comparisons of the AEDs to the non-drug conditions were made as secondary analyses. For these analyses, the non-drug data were collapsed across the non-drug states (e.g., baseline, first drug washout period, and second drug washout period) to create an average non-drug condition (non-drug). Paired samples *t* tests were used to compare the overall score between the non-drug and each AED. Follow-up analyses comparing the AEDs and non-drug states across individual variables were conducted using paired *t* tests.

Finally, sensitivity and specificity for detecting the effects of LEV and CBZ was analyzed using stepwise linear discriminant analysis (LDA) with a leave-out-one case jackknife cross-validation. In all cases, the LDA was restricted to a maximum of four variables provided by the different assessment instruments to avoid over-fitting the data.

**RESULTS Subjects.** A total of 49 subjects were enrolled (35 at MCG and 14 at GU). Five subjects were screen failures, and two withdrew consent for personal reasons prior to drug randomization. Of the 42 subjects randomized, two withdrew for personal reasons prior to receiving any drug (figure 2). Of those begun on AED, 12 subjects withdrew from the study (5 on CBZ, 5 on LEV, and 2 off drug during the washout period between AEDs). Reasons for the five subjects who withdrew from CBZ included one for skin rash, one for nausea, one for migraines, and three withdrew consent for personal reasons (e.g., noncompliance). Reasons for the five subjects who withdrew

**Table 1** Means (SD) of neuropsychological measures for carbamazepine (CBZ) and levetiracetam (LEV) and non-drug average

Variables	CBZ	LEV	Non-drug
Overall composite score	-0.40 (0.27)	-0.02 (0.29) <sup>C</sup>	0.14 (0.10) <sup>C,L</sup>
SAM examination (cognitive-neurophysiologic test score)	-0.53 (0.23)	0.10 (0.24) <sup>C</sup>	0.14 (0.09) <sup>C</sup>
Standard neuropsychological tests by domains			
Attention/vigilance			
Digit Cancellation	187 (37)	194 (40)	192 (32)
Trial 1 Visual Serial Addition Test	56 (4)	56 (7)	57 (4)
Trial 2 Visual Serial Addition Test	54 (7)	56 (7)	56 (5) <sup>C</sup>
Trial 3 Visual Serial Addition Test	53 (7)	54 (7)	55 (6) <sup>C</sup>
Trial 4 Visual Serial Addition Test	50 (9)	52 (8) <sup>C</sup>	53 (8) <sup>C</sup>
Total Visual Serial Addition Test	214 (25)	217 (27)	221 (22) <sup>C,L</sup>
Memory			
MCG Paragraphs: Immediate Recall 1	30 (16)	32 (15)	33 (15)
MCG Paragraphs: Immediate Recall 2	48 (23)	49 (21)	50 (19)
MCG Paragraphs: Delay Recall	50 (24)	50 (24)	52 (21)
Cognitive/motor speed			
Choice Reaction Time-Initiation*	437 (104)	421 (80)	407 (71) <sup>C</sup>
Choice Reaction Time-Movement*	197 (99)	213 (81)	212 (76)
Choice Reaction Time-Total*	635 (88)	635 (99)	625 (92)
Grooved Pegboard*	62 (10)	60 (12)	59 (8) <sup>C</sup>
Other cognitive			
Stroop: Word	101 (18)	105 (15) <sup>C</sup>	106 (15) <sup>C</sup>
Stroop: Color	77 (14)	82 (11) <sup>C</sup>	83 (11) <sup>C</sup>
Stroop: Word/Color	48 (12)	50 (11)	51 (11) <sup>C</sup>
Symbol Digit Modalities Test	57 (13)	58 (12)	61 (13) <sup>C,L</sup>
Subjective measures			
AB Neurotoxicity*	14 (11)	9 (11) <sup>C</sup>	5 (8) <sup>C,L</sup>
POMS-Tension*	7 (5)	6 (6)	5 (3) <sup>C</sup>
POMS-Depression*	6 (7)	3 (7)	3 (5) <sup>C</sup>
POMS-Anger*	6 (6)	4 (7)	3 (4) <sup>C</sup>
POMS-Vigor	15 (5)	19 (6) <sup>C</sup>	20 (5) <sup>C</sup>
POMS-Fatigue*	9 (6)	6 (6) <sup>C</sup>	4 (3) <sup>C</sup>
POMS-Confusion*	7 (4)	5 (5) <sup>C</sup>	4 (3) <sup>C</sup>
POMS-Total*	20 (26)	5 (31) <sup>C</sup>	-2 (19) <sup>C</sup>
QOLIE-Attention/Concentration	80 (18)	87 (14) <sup>C</sup>	90 (12) <sup>C</sup>
QOLIE-Language	89 (11)	94 (12) <sup>C</sup>	94 (8) <sup>C</sup>
QOLIE-Memory	71 (24)	83 (17) <sup>C</sup>	85 (16) <sup>C</sup>
SEALS-Dysphoria*	4 (3)	2 (2) <sup>C</sup>	2 (2) <sup>C</sup>
SEALS-Tiredness*	4 (3)	3 (2) <sup>C</sup>	2 (1) <sup>C,L</sup>
SEALS-Temper*	2 (2)	2 (2)	2 (1) <sup>C</sup>
SEALS-Cognition*	9 (5)	6 (5) <sup>C</sup>	5 (4) <sup>C</sup>
SEALS-Worry*	3 (2)	3 (2)	3 (1)

Superscripts refer to statistical differences: C = significantly better than carbamazepine; L = significantly better than levetiracetam.

\*Variables for which lower mean values indicate better performance.

SAM = Sustained Attention and Memory; MCG = Medical College of Georgia; POMS = Profile of Mood States; QOLIE = Quality of Life in Epilepsy-89; SEALS = Side Effects and Life Satisfaction Scale.

**Figure 2** Trial profile for randomization, first treatment, washout, crossover to second treatment, and final washout

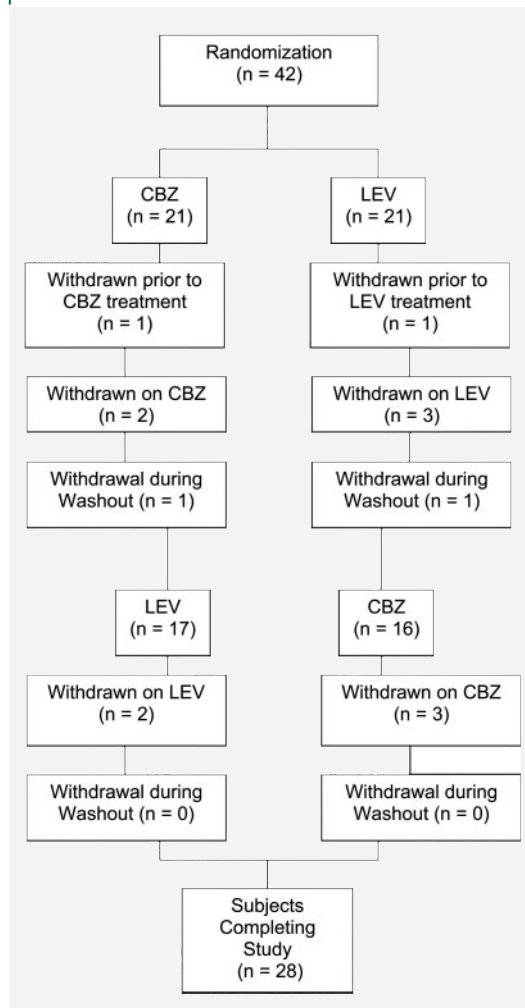

CBZ = carbamazepine; LEV = levetiracetam.

from LEV included one for skin rash, one for irritability, one for accidental aspirin overdose (no sequelae), and two withdrew consent for personal reasons. The two subjects who withdrew during the washout (one post CBZ treatment and one post LEV treatment) were both for personal reasons (e.g., moved to new city or felt the study was too much trouble). Thus, there were 28 subjects who completed the entire study. Demographics for this group were as follows: mean age = 33 years (range = 18 to 51); 17 women; 11 men. Mean IQ of the subjects was 125.<sup>40</sup>

**AEDs.** The dose of LEV was 2,000 mg/day and mean ( $\pm$ SD) ABL for LEV on the day of neuropsychological testing was 32.2 mcg/mL (11.2). The mean ( $\pm$ SD) CBZ daily dose was 564 mg/day (110), and the mean ( $\pm$ SD) ABL for CBZ on the day of neuropsychological testing was 7.5 mcg/mL (1.5).

**Primary analysis.** The direct comparison of CBZ vs LEV using the overall variable revealed a main effect for drug [ $F(1,26) = 15.21, p \leq 0.001$ ], but no effect for order [ $F(1,26) = 0.53, NS$ ] and no interaction of drug  $\times$  order [ $F(1,26) = 2.00, NS$ ]. Follow-up analyses comparing the two AEDs across individual variables revealed significantly worse effects for CBZ on 44% (15 of 34) of the variables (table 1 and table E-1 on the *Neurology*<sup>®</sup> Web site at [www.neurology.org](http://www.neurology.org)).

**Test-retest effects of non-drug states.** Using a linear-trend analysis of the overall score, subjects were shown to improve across non-drug conditions [ $F(1,26) = 15.04, p \leq 0.001$ ]. This “practice” effect was driven by the five domains comprising the standard neuropsychological tests [ $F(1,27) = 19.79, (p \leq 0.001)$ ] and was not present for the cognitive neurophysiologic test [ $F(1,26) = 3.04, NS$ ]. It should be noted that this effect does not present a significant confound for interpreting the main effects of drug, given that drug order was counterbalanced and there was no main effect of order or a drug  $\times$  order interaction. We therefore collapsed the non-drug data to create an average non-drug condition (non-drug) to compare to the AED states.

**Comparing drug and non-drug states.** Both CBZ ( $p \leq 0.001$ ) and LEV ( $p \leq 0.05$ ) differed from non-drug on the overall score. Follow-up analyses comparing the two AEDs to non-drug across individual variables revealed significantly worse effects on 76% (26 of 34) of the variables for CBZ and 12% (4 of 34) for LEV compared to non-drug (tables 1 and E-1).

**Cognitive-neurophysiologic effects.** Follow-up analyses were conducted on the electrophysiologic components of the SAM examination to provide some details on these effects. The impact of the AEDs on the EEG/ERP are shown in figure 3A. In comparison with the non-drug average and LEV conditions, CBZ increased EEG power across the spectrum for all task conditions, with the largest increase in the 2–10 Hz band. Since this effect was apparent at all electrode sites, it was analyzed at the midline parieto-occipital site (POz) for convenience. Power in the 2–10 Hz band was larger for CBZ than for LEV or the non-drug average ( $p < 0.001$ ). There was no difference between LEV and the non-drug average.

The effect of the AEDs on the ERPs in the working memory and word recognition tasks is shown in figure 3B. In the working memory task, the most prominent ERP peak, P300, was larger for CBZ than for LEV or the non-drug average

**Figure 3** Effects of carbamazepine (CBZ) and levetiracetam (LEV) on EEG power spectra, event-related potentials (ERPs) in the working memory task, and ERPs in the word recognition task

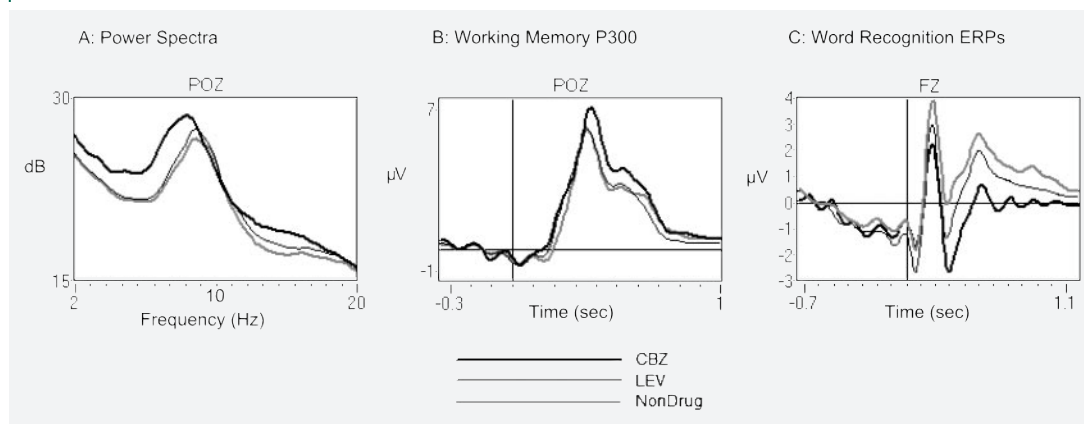

Effects of CBZ and LEV on A) EEG power spectra, averaged across all tasks. Relative to LEV and non-drug, CBZ significantly increased EEG power below 10 Hz; B) ERPs in the working memory task. Relative to LEV and non-drug, P300 amplitude and latency were significantly increased by CBZ; C) ERPs in the word recognition task. CBZ significantly decreased the frontal slow wave relative to LEV or the non-drug average. Relative to the non-drug average, LEV had a significantly larger frontal slow wave.

( $p < 0.01$ ) (figure 3B). P300 peak latency was later for CBZ than for the non-drug average, by an average of 27 msec ( $p < 0.01$ ). The frontal slow wave ERP in the word recognition task conditions was smaller for CBZ than for LEV and non-drug conditions ( $p < 0.001$ ; figure 3C). Relative to the non-drug average, LEV had a larger frontal slow wave ( $p < 0.001$ ).

**Sensitivity and specificity for detecting drug effects.** Stepwise LDA, using a leave-out-one case jack-knife cross-validation, was used to characterize the sensitivity and specificity with which the cen-

tral effects of LEV and CBZ could be detected using the variables provided by the different assessment instruments. LDAs were restricted to a maximum of four variables to avoid over-fitting the data. The results of these analyses are summarized in table 2. In brief, an LDA using the five domains compiled from the battery of conventional neuropsychological tests and subjective questionnaires discriminated CBZ from LEV with a cross-validated sensitivity of 75% and specificity of 75% (area under the ROC curve = 0.888;  $p < 0.001$ ). In contrast, an LDA using variables comprising the SAM examination achieved a cross-validated sensitivity of 96% and specificity of 100% for discriminating CBZ from LEV (area under the ROC curve = 1;  $p < 0.001$ ).

Although the primary aim of the study was to directly compare the two AEDs, this approach was also effective at discriminating each AED from the non-drug state. In particular, an LDA using the conventional neuropsychological test domains as variables discriminated CBZ from the non-drug conditions, with a cross-validated sensitivity of 89% and specificity of 96% (area under the ROC curve = 0.997;  $p < 0.001$ ). An LDA that used variables comprising the SAM examination achieved a cross-validated sensitivity of 100% and specificity of 100% for discriminating CBZ from the non-drug conditions (area under the ROC curve = 1;  $p < 0.001$ ). In contrast, discrimination of LEV from the non-drug conditions had lower sensitivities and specificities. An LDA discriminating LEV from the non-drug conditions using domains taken from the battery of conven-

**Table 2** Sensitivity and specificity for discriminating carbamazepine (CBZ) from levetiracetam (LEV), and each antiepileptic drug from the non-drug average using domains computed from standard (Std.) neuropsychological tests and variables from the Sustained Attention and Memory (SAM) examination cognitive-neurophysiologic test

	Sensitivity	Specificity	Goodness of fit
<b>CBZ vs LEV</b>			
Std. neuropsychological tests	75	75	Area under curve = 0.888
SAM examination	96	100	Area under curve = 1
<b>CBZ vs non-drug</b>			
Std. neuropsychological tests	89	96	Area under curve = 0.997
SAM examination	100	100	Area under curve = 1
<b>LEV vs non-drug</b>			
Std. neuropsychological tests	46	82	Area under curve = 0.675; $p \leq 0.05$
SAM examination	75	93	Area under curve = 0.858

For CBZ vs LEV comparisons, sensitivity refers to percent of CBZ data correctly classified, and specificity refers to percentage of LEV data correctly classified. For antiepileptic drug vs non-drug comparisons, sensitivity refers to percentage of on-drug data correctly classified, and specificity to the percentage of non-drug data correctly classified. Unless otherwise noted, all classifications are significant at  $p \leq 0.001$ .

tional neuropsychological tests as variables had a cross-validated sensitivity of 46% and specificity of 82% (area under the ROC curve = 0.675;  $p < 0.05$ ). Using the variables comprising the SAM examination, LEV vs non-drug sensitivity was 75% with a specificity of 93% (area under the ROC curve = 0.858;  $p < 0.001$ ).

**DISCUSSION** The present study demonstrates that LEV produces fewer untoward neuropsychological and neurophysiologic side effects than CBZ in monotherapy at the dosages, titrations, and timeframes employed in this study. Performance on LEV was better across a broad spectrum of measures including attention/vigilance, memory, language, cognitive/motor speed, graphomotor coding, reading/naming speed, subjective behavioral, and the cognitive-neurophysiologic tests. These results are comparable to studies with similar design and neuropsychological variables comparing gabapentin and lamotrigine to CBZ.<sup>4,24-25</sup>

Levetiracetam has a favorable safety profile, but adverse behavioral side effects have been reported including irritability, agitation, and aggressive behavior.<sup>43</sup> These adverse effects appear to be more likely to occur in patients with learning disability or those with prior psychiatric history.<sup>43</sup> In contrast, a systematic review demonstrated that LEV was well tolerated in four large, well studied cohorts with a relatively low incidence of behavioral adverse events.<sup>44</sup> In the present study, there was one dropout in the LEV group due to irritability. However, no differences were present between the two AEDs for tension, depression, or anger on the POMS or for temper on the SEALS. Overall across the POMS, SEALS, and QOLIE variables, 10/15 were significantly better for LEV over CBZ, 14/15 for non-drug over CBZ, and 1/15 for non-drug over LEV. Thus, there is little evidence from these data to support greater behavioral effects of LEV although results in this healthy adult population may not apply to other populations.

Neurophysiologic changes were present during CBZ treatment, most prominently increased low frequency EEG power. Such EEG changes can be associated with reduced alertness. Ratings on the POMS and SEALS subjective scales indicated that CBZ was associated with reduced subjective alertness. However, other neurophysiologic indicators of reduced alertness, such as a decrease in resting state, eyes closed alpha power, or an increase in slow rolling eye movements, were not present in the data, making it unlikely that the general increase in EEG power below 10 Hz that occurred following treat-

ment with CBZ is due solely to decreased alertness. This increase is similar to that which has been described in previous reports of the steady-state effects of CBZ, as well as those of gabapentin, oxcarbazepine, phenytoin, and topiramate.<sup>3-4,6,22,45</sup> Increased low frequency EEG activity has been described as characteristic of encephalopathies arising from metabolic disorders, disease processes, drug effects, or exposure to neurotoxins.<sup>46,47</sup>

In the present study, discriminant analysis detected the central effects of LEV and CBZ in most individual participants in cross-validated analyses. Sensitivity and specificity for detecting CBZ relative to the non-drug condition was higher than LEV to non-drug. Although highly accurate detection of CBZ could be obtained with variables from conventional neuropsychological tests, discriminant analyses including EEG variables were able to detect treatment with CBZ with perfect sensitivity and specificity. This result is consistent with other recent reports indicating that inclusion of EEG measures can improve the ability to detect the central effects of drugs over and above that which can be obtained by behavioral measures alone.<sup>6-7,9-13,18</sup> The improved specificity and sensitivity, or rather, experimental power, afforded by inclusion of EEG measures in such assessments, could, for example, decrease the sample size needed for detecting significant effects in future clinical trials aimed at characterizing the central effects of pharmacologic interventions. Further, combined cognitive and EEG measures may help delineate the mechanisms underlying the cognitive effects of drugs.

The negative cognitive effects of AEDs are especially important to those who require maximal cognitive efficiency for their job, school, or other daily activities. This study indicates that LEV has fewer cognitive side effects than CBZ in monotherapy at the dosages, titrations, and timeframes employed in this study. The dosages of CBZ and LEV in the present study are commonly used in clinical settings; however, equivalent dosages for CBZ and LEV are uncertain. The magnitude of differences for some individuals in the present study, the reduction in performance measures with higher blood levels, and the fact that differential treatment effects could be accurately detected at the level of the individual subject in all participants suggest that the differences are clinically significant. Nevertheless, negative cognitive and behavioral side effects of an AED are not the only consideration in the choice of AED. Efficacy, systemic side effects, dosage forms, and cost may also affect AED choice. The physician's goal for



the individual patient is to balance these various considerations in order to obtain seizure freedom, minimize side effects, and maximize the patient's quality of life. The present study provides information on the relative cognitive and behavioral effects of LEV and CBZ that could assist physicians and their patients in making treatment decisions.

Received July 10, 2006. Accepted in final form June 5, 2007.

## REFERENCES

1. Cereghino JJ, Biton V, Abou-Khalil B, Dreifuss F, Gauer LJ, Leppik I. Levetiracetam for partial seizures: results of a double-blind, randomized clinical trial. *Neurology* 2000;55:236–242.
2. Chaisewikul R, Privitera MD, Hutton JL, Marson AG. Levetiracetam add-on for drug-resistant localization related (partial) epilepsy (Cochrane Review). *Cochrane Database Syst Rev* 2001;1:CD001901.
3. Mecarelli O, Vicenzini E, Pulitano P, et al. Clinical, cognitive, and neurophysiologic correlates of short-term treatment with carbamazepine, oxcarbazepine, and levetiracetam in healthy volunteers. *Ann Pharmacother* 2004;38:1816–1822.
4. Salinsky MC, Binder LM, Oken BS, Storzbach D, Aron CR, Dodrill CB. Effects of gabapentin and carbamazepine on EEG and cognition in healthy volunteers. *Epilepsia* 2002;43:482–490.
5. Chung SS, McEvoy LK, Smith ME, Gevins A, Meador K, Laxer KD. Task related EEG & ERP changes without performance impairment following a single dose of phenytoin. *Clin Neurophysiol* 2002;113:806–814.
6. Smith ME, Gevins A, McEvoy LK, Meador KJ, Ray PG, Gilliam F. Distinct cognitive neurophysiologic profiles for lamotrigine and topiramate. *Epilepsia* 2006;47:695–703.
7. Gevins A, Smith ME, McEvoy LK. Tracking the cognitive pharmacodynamics of psychoactive substances with combinations of behavioral and neurophysiological measures. *Neuropsychopharmacology* 2002;26:27–39.
8. Smith ME, McEvoy LK, Gevins A. The impact of moderate sleep loss on neurophysiologic signals during working memory task performance. *Sleep* 2002;25:784–794.
9. McEvoy LK, Smith ME, Fordyce M, Gevins A. Characterizing impaired functional alertness from diphenhydramine in the elderly with performance and neurophysiologic measures. *Sleep* 2006;29:959–966.
10. Gevins A, Smith ME. Detecting transient cognitive impairment with EEG pattern recognition methods. *Aviation Space Environ Med* 1999;70:1018–1024.
11. Ilan AB, Gevins A. Prolonged neurophysiological effects of cumulative wine drinking. *Alcohol* 2001;25:137–152.
12. McEvoy LK, Chellaramani R, Smith ME, Gevins A. Effects of a benzodiazepine on behavioral and neurophysiological measures of working memory. *Soc Neurosciences* 2001:117. Abstract.
13. Ilan AB, Smith ME, Gevins A. Effects of marijuana on neurophysiological signals of working and episodic memory. *Psychopharmacology* 2004;176:214–222.
14. Gevins A, Smith ME, Le J, et al. High resolution evoked potential imaging of the cortical dynamics of human working memory. *Electroencephalogr Clin Neurophysiol* 1996;98:327–348.
15. Gevins A, Smith ME, McEvoy L, Yu D. High resolution EEG mapping of cortical activation related to working memory: Effects of task difficulty, type of processing, and practice. *Cereb Cortex* 1997;7:374–385.
16. McEvoy L, Smith ME, Gevins A. Dynamic cortical networks of verbal and spatial working memory. *Cereb Cortex* 1998;8:563–574.
17. Kushida CA, Nichols DA, Quan SF, et al. The Apnea Positive Pressure Long-term Efficacy Study (APLES): rationale, design, methods, and procedures. *J Clin Sleep Med* 2006;2:288–300.
18. Ilan AB, Gevins A, Coleman M, ElSohly MA, de Wit H. Neurophysiological and subjective profile of marijuana with varying concentrations of cannabinoids. *Behav Pharmacol* 2005;16:487–496.
19. Gevins A, Smith ME. Neurophysiological measures of working memory and individual differences in cognitive ability and cognitive style. *Cereb Cortex* 2000;10:829–839.
20. Meador KJ. Cognitive effects of epilepsy and of anti-epileptic medications. In: Wyllie E, ed. *The treatment of epilepsy. Principles and practices*, 4th edition. Philadelphia: Lippincott Williams & Wilkins, 2005:1185–1195.
21. Meador KJ, Loring DW, Allen ME, et al. Comparative cognitive effects of carbamazepine and phenytoin in healthy adults. *Neurology* 1991;41:1537–1540.
22. Meador KJ, Loring DW, Abney OL, et al. Effects of carbamazepine and phenytoin on EEG and memory in healthy adults. *Epilepsia* 1993;34:153–115.
23. Meador KJ, Loring DW, Moore EE, et al. Comparative cognitive effects of phenobarbital, phenytoin and valproate in healthy subjects. *Neurology* 1995;45:1494–1499.
24. Meador KJ, Loring DW, Ray PG, et al. Differential cognitive effects of carbamazepine and gabapentin. *Epilepsia* 1999;40:1279–1285.
25. Meador KJ, Loring DW, Ray PG, et al. Differential cognitive and behavioral effects of carbamazepine and lamotrigine. *Neurology* 2001;8:1177–1182.
26. Meador KJ, Loring DW, Vahle VJ, et al. Cognitive and behavioral effects of lamotrigine and topiramate in healthy volunteers. *Neurology* 2005;64:2108–2114.
27. Dunn LM, Dunn LM. *Peabody Picture Vocabulary Test—Third Edition*. Circle Pines, MN: American Guidance Services, 1997.
28. Dodrill CB, Arnett JL, Sommerville KW, Sussman NM. Effects of differing dosages of vigabatrin (Sabril) on cognitive abilities and quality of life in epilepsy. *Epilepsia* 1995;36:164–173.
29. Lezak MD, Howieson DB, Loring DW. *Neuropsychological Assessment*, 4th edition. New York: Oxford University Press, 2004.
30. Lachman R, Lachman JL, Butterfield EC. *Cognitive psychology and information processing: an introduction*. Hillsdale, NJ: Lawrence Erlbaum, 1979.
31. Golden CJ. *Stroop Color and Word Test. A manual for clinical and experimental uses*. Chicago: Stoelting, 1978.
32. Smith A. *Symbol Digit Modalities Test. Manual*. Los Angeles: Western Psychological Services, 1973.

33. Aldenkamp AP, Baker G, Pieters MS, Schoemaker HC, Cohen AF, Schwabe S. The Neurotoxicity Scale: the validity of a patient-based scale assessing neurotoxicity. *Epilepsy Res* 1995;20:229–239.
34. Lorr M, McNair DM, Droppleman LF. *Manual: Profile of Mood States*. San Diego, CA: Educational and Industrial Testing Service, 1971.
35. Gillham R, Baker G, Thompson P, et al. Standardisation of a self-report questionnaire for use in evaluating cognitive, affective and behavioural side-effects of anti-epileptic drug treatments. *Epilepsy Res* 1996;24:47–55.
36. Devinsky O, Vickrey BG, Cramer J, et al. Development of the Quality of Life in Epilepsy (QOLIE) Inventory. *Epilepsia* 1995;36:1089–1104.
37. Smith ME, Stapleton JM, Halgren E. Human medial temporal lobe potentials evoked in memory and language tasks. *Electroencephalogr Clin Neurophysiol* 1986;63:145–159.
38. Smith ME, Halgren E. Dissociation of recognition memory components following temporal lobe lesions. *J Exp Psychol Learning Memory Cogn* 1989;15:50–60.
39. Smith ME. Neurophysiological manifestations of recollective experience during recognition judgments. *J Cog Neurosci* 1993;5:1–13.
40. Smith ME, Guster K. Decomposition of recognition memory event-related potentials yields target, repetition, and retrieval effects. *Electroencephalogr Clin Neurophysiol* 1993;86:335–343.
41. Rugg MD, Yonelinas AP. Human recognition memory: a cognitive neuroscience perspective. *Trends Cogn Sci* 2003;7:313–319.
42. Hermann WM. *Electroencephalography in Drug Research*. New York: Gustav Fischer Verlag, 1982.
43. Abou-Khalil B. Benefit-risk assessment of levetiracetam in the treatment of partial seizures. *Drug Safety* 2005;28:871–890.
44. Cramer JA, De Rue K, Devinsky O, Edrich P, Trimble MR. A systematic review of the behavioral effects of levetiracetam in adults with epilepsy, cognitive disorders, or an anxiety disorder during clinical trials. *Epilepsy Behav* 2003;4:124–132.
45. Salinsky MC, Spencer DC, Oken BS, Storzbach D. Effects of oxcarbazepine and phenytoin on the EEG and cognition in healthy volunteers. *Epilepsy Behav* 2004;5: 894–902.
46. Ikeda A, Klem GH, Luders HO. Metabolic, infectious, and hereditary encephalopathies. In: Ebersole JS, Pedley TA, eds. *Current practice of clinical electroencephalography*. Philadelphia, PA: Lippincott Williams, & Wilkins, 2003:348–377.
47. Van Cott AC, Brenner RP. Drug effects and toxic encephalopathies. In: Ebersole JS, Pedley TA, eds. *Current practice of clinical electroencephalography*. Philadelphia, PA: Lippincott Williams & Wilkins, 2003:463–482.

## New Guideline Recommends When to Use CT Scans in ED for Seizures

A guideline developed by the American Academy of Neurology recommends immediate brain CT scans to screen certain emergency department patients with seizures. Evidence shows such scans can help doctors select the right treatment option. The guideline—a reassessment of the AAN’s 1996 guideline—was published in the October 30, 2007, issue of *Neurology*<sup>®</sup>. Visit [www.aan.com](http://www.aan.com) to read the full guideline.

**Neuropsychological and neurophysiologic effects of carbamazepine and levetiracetam**

K. J. Meador, A. Gevins, D. W. Loring, L. K. McEvoy, P. G. Ray, M. E. Smith, G. K. Motamedi, B. M. Evans and C. Baum

*Neurology* 2007;69;2076-2084

DOI: 10.1212/01.wnl.0000281104.55418.60

**This information is current as of November 27, 2007**

**Updated Information & Services**

including high-resolution figures, can be found at:  
<http://www.neurology.org/cgi/content/full/69/22/2076>

**Supplementary Material**

Supplementary material can be found at:  
<http://www.neurology.org/cgi/content/full/69/22/2076/DC1>

**Subspecialty Collections**

This article, along with others on similar topics, appears in the following collection(s):  
**All Neuropsychology/Behavior**  
[http://www.neurology.org/cgi/collection/all\\_neuropsychology\\_behavior](http://www.neurology.org/cgi/collection/all_neuropsychology_behavior) **All clinical neurophysiology**  
[http://www.neurology.org/cgi/collection/all\\_clinical\\_neurophysiology](http://www.neurology.org/cgi/collection/all_clinical_neurophysiology) **Antiepileptic drugs**  
[http://www.neurology.org/cgi/collection/antiepileptic\\_drugs](http://www.neurology.org/cgi/collection/antiepileptic_drugs) **EEG**  
<http://www.neurology.org/cgi/collection/eeg>

**Permissions & Licensing**

Information about reproducing this article in parts (figures, tables) or in its entirety can be found online at:  
<http://www.neurology.org/misc/Permissions.shtml>

**Reprints**

Information about ordering reprints can be found online:  
<http://www.neurology.org/misc/reprints.shtml>

